

Assembly, Operating & Maintenance Instructions

Staples Canteshire Executive Chair



Re-Order Code: 18808575

Remove all items from the carton. Verify all pieces before assembly.

PARTS LIST

KEY	QTY	DESCRIPTION
1	5	Castors
2	1	Base
3	1	Gas Lift
4	1	Gas Lift bellows
5	1	Seat
6	1	Seat Mechanism
7	1	Allen Wrench
8	1	Back
9	2	Armrests
10	8	Armrest Screws 1/4" x 25
11	8	Armrest Caps

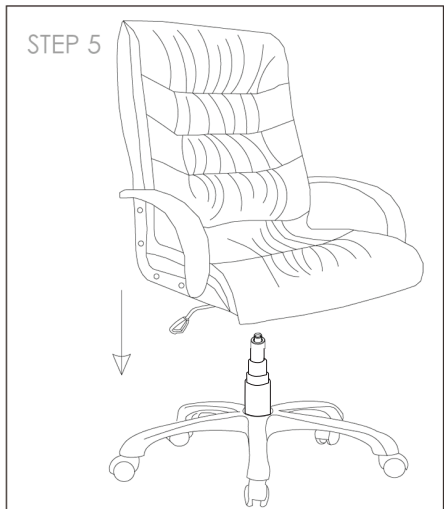
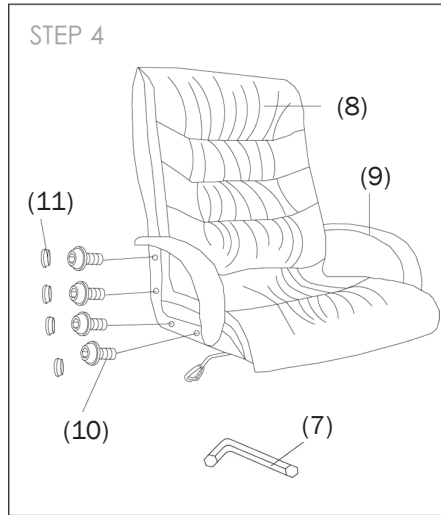
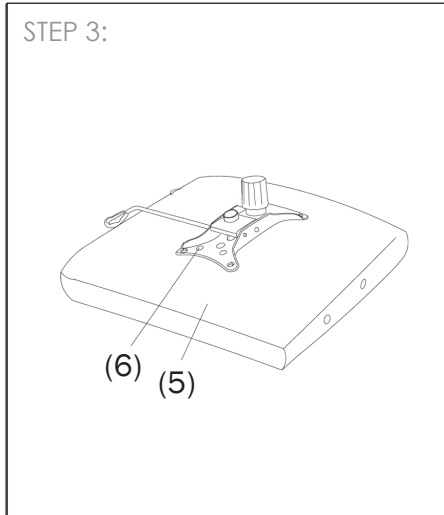
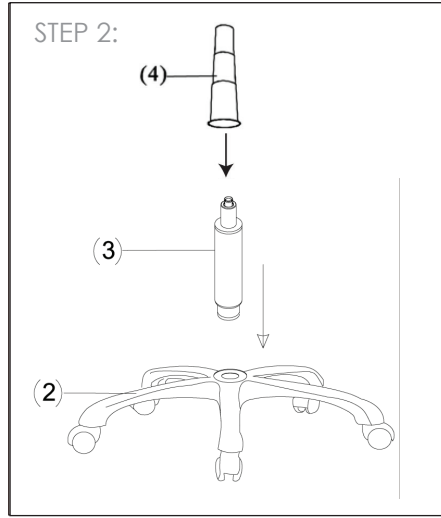
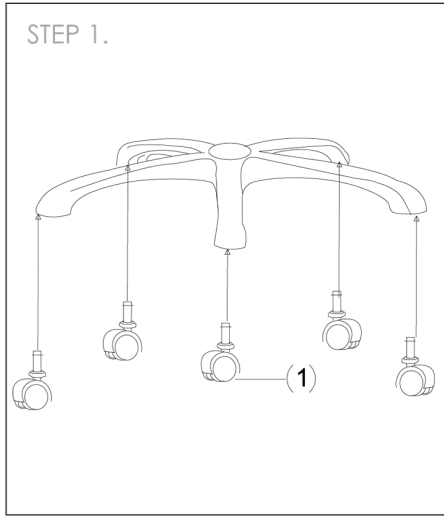

MECHANISM OPERATING INSTRUCTIONS IMPORTANT NOTE:
Do not operate the mechanism levers unless properly seated in the chair.

A Seat height adjustment, Tilt & Lock adjustment
B Knob for back tension spring adjustment

CARE & MAINTENANCE

GENERAL CARE

- To maintain the appearance of non-upholstered parts wipe the surface with a clean cloth dampened with a mild detergent solution
- Do not remove any parts for separate cleaning
- Do not saturate the fabric or interior with water or other cleaning liquids
- Do not shampoo clean
- Do not clean with hot water extraction machine
- Do not clean with onsite drycleaning machine
- Protect from direct sunlight, heat and weather.

UPHOLSTERY CARE FOR BONDED LEATHER

- Wipe with a clean cloth dampened with a mild upholstery detergent solution
- A soft bristle brush may be used to remove ingrained soil
- Use only leather care products suitable for top coated leather and strictly in accordance with the manufacturer's instructions
- Spot clean as above
- Treat spills and stains as soon as possible
- Persistent stains may require treatment by a professional cleaner
- Allow to dry thoroughly before reuse.

UPHOLSTERY & FOAM SPECS

FOAM

Flame Resistant: Ca117 Section A Part I & Section D Part II

Bonded leather is Polyurethane upholstery bonded to regenerated leather.

Flame Resistance: Ca117 Section E Class I

RECOMMENDED SEATING POSITION & OPERATING INSTRUCTIONS:

To ensure maximum enjoyment, comfort & safety when using this chair, please familiarise yourself with the following recommended seating positions & operating Instructions as detailed below;

1. Sit on the chair to operate the chair functions

2. Lift the right hand 'gaslift/tilt lever paddle' (A) to lower the seat to the desired seat height position. To raise the seat, lift the 'right hand' gaslift/tilt lever paddle' (A) while supporting your own weight off the seat.

NOTE: A suitable seat height position maybe influenced by your working environment e.g. the height of the work surface. Your forearms should be as close to horizontal as possible when working at your work surface & your feet should resting flat on the floor or on a solid surface.

3. Identify the 'tension adjustment knob' (B), a functional part of the seat mechanism located under the seat. Turn the tension adjustment knob (B) anti-clockwise for more back resistance or clockwise for less back resistance until the desired level of back resistance is found.

NOTE: The correct back resistance is personal to the user however the ideal back tilt tension is recognisable when the chair back requires a reasonable force to push back in an unlocked seat tilt position.

4. While sitting on your chair 'pull out' the gaslift/tilt lever paddle (A) i.e. sideways from left to right away from the seat. Do not put any weight on the back while carrying out this operation. Check the back tilt is unlocked by sitting on the chair and carefully leaning back on the chair back. The back should tilt rearward.

5. While sitting on your chair, return the back to the upright position by releasing all weight from the back of the chair. 'Push In' the gaslift/tilt lever paddle (A) i.e. sideways from right to left towards the seat and the back will lock into forward position.

Special Note: To ensure correct chair operation and best seating results, the gaslift/tilt lever paddle (A) must be in the 'unlocked position' (refer point 4 above) when choosing to recline. **Any forced operation of the back angle when the gaslift/tilt lever paddle is in the 'locked position' may seriously damage your chair.**

PREVENTATIVE MAINTENANCE & WARNING!

- Do not use this chair as a step stool/ladder.
- Do not sit on any part of the chair except the seat.
- Do not use this chair on uneven floor surfaces.
- Do not open, heat up or interfere with the operation of the gas lift
- Do not use chair unless all bolts, screws and knobs are tight. At least every three months check all bolts, screws and knobs to ensure they are tight.
- If any parts are missing, broken, damaged or worn do not use the product until repairs are made using factory authorised parts.

- Dispose of packaging properly.
- Plastic bags used for packaging are not toys.
- Do not use plastic bag as a head covering as it may cause suffocation.
- Failure to follow these warnings could result in serious injury.
- Use this product only for seating one person at a time.
- Indicative Weight Usage: 110kg
- Indicative daily sitting hours: 4-6 hrs