

*Environmental Information Document
Australian Manufacture*

POLYPROPYLENE



Introduction

This Environmental Information Document (EID) is based upon life cycle inventory (LCI) data generated for Australian Polypropylene (PP) manufacture. The study was commissioned by LyondellBasell Australia Pty Ltd and conducted by RMIT Centre for Design, data has been peer reviewed in accordance with ISO14040/14044 by Franklin Associates. Environmental performance data is detailed within; there is no information on the economic or social aspects which would be necessary for a complete sustainability assessment. Furthermore, it does not imply a value judgment between environmental criteria.

This guide describes the current Australian situation regarding the production, use and end of life situations for PP polymer and articles. The LCI data quoted within relates to Australian manufactured Polypropylene from *well to gate* (crude oil extraction to plastic pellets out the Polypropylene plant). It is important to recognise that comparisons by weight of materials should not be made. It is necessary to consider the full life cycle of an application in order to compare the performance of different materials and the effects of relevant life cycle parameters.

This EID is intended as a source of general information to support product based environmental management and for users of plastics and interested parties as a source of life cycle information. This document is not suited for use in detailed LCA studies, in such cases the use of the full LCI data is required and is now available within the AUSLCI database. The AUSLCI database is compatible with LCA software packages commonly used in Australia.

LCA is the preferred tool to analyse the environmental efficiency of the complete cradle to grave life cycle of most systems or products. It can be instrumental in the design of systems, in product design optimisation, material selection and end of life considerations.

Description of the Product and the Production Process

Product

Polypropylene (PP) is a resin of the polyolefin family and is one of the most widely used plastics in the world today, with a density of only 0.9 g/cm³, it is also the lightest of the widely used thermoplastics. The low density characteristic of PP is a key factor enabling lighter weighting of many end applications relative to using higher density materials. Light weighting and the resulting reduced material usages are often important drivers of LCA environmental impact results.

PP has outstanding chemical resistance - the best of all thermoplastics to organic chemicals, in fact there is no solvent for polypropylene at room temperature, although it may swell in some cases. It is basically flammable and ignites at a temperature of about 350°C. Although its burning rate is slow when tested to ASTM D635, it can be made flame-retardant by incorporating suitable additives. When used in applications involving extended UV and outdoor exposure, PP will require the addition of UV stabilising additives.

PP is a versatile material that can be easily processed via injection molding, blow moulding, extrusion and thermoforming techniques into a diverse range of industrial and consumer applications.

Production process

PP is produced commercially from olefin (alkene) monomers which contain a reactive carbon to carbon double bond. The starting material, propylene, is called the monomer and the final product consisting of many thousands of bound propylene units is called the polymer. Co-monomers (ethylene, butene) are used to improve toughness, impact resistance and transparency (random co-polymers). Two techniques are used for the production of polypropylene within Australia:

Liquid Propylene Pool Process (LIPP): The polymer is produced in a liquid pool of propylene by the inclusion of a Ziegler Natta catalyst which forces the molecules of the monomer to align and join in a certain manner to enable long chain formation, or polymerisation, into polypropylene. When long chain formation is sufficient, growth of the molecule is stopped via hydrogen, following this the catalyst is deactivated and resultant polymer separated from the liquid propylene.

Gas Phase Polymerisation: A gas phase reactor is essentially a fluidised bed of dry polymer particles maintained either by stirring or by passing the propylene monomer gas at high speeds through it. As with the LIPP process, high activity speciality catalysts are used in the polymerisation of the gaseous monomer into polypropylene. Pressures are usually relatively low at ~2MPa and temperatures are usually in the range 60 – 80°C.

In both processes, the polypropylene leaving the reactor is in a fine powder form. This powder is then mixed with various chemical stabilising and performance additives, fed to an extrusion compounding machine which melt mixes the materials and forces the melt through dies where it is cut into pellets, the molten pellets are then cooled using water then packaged for sale.

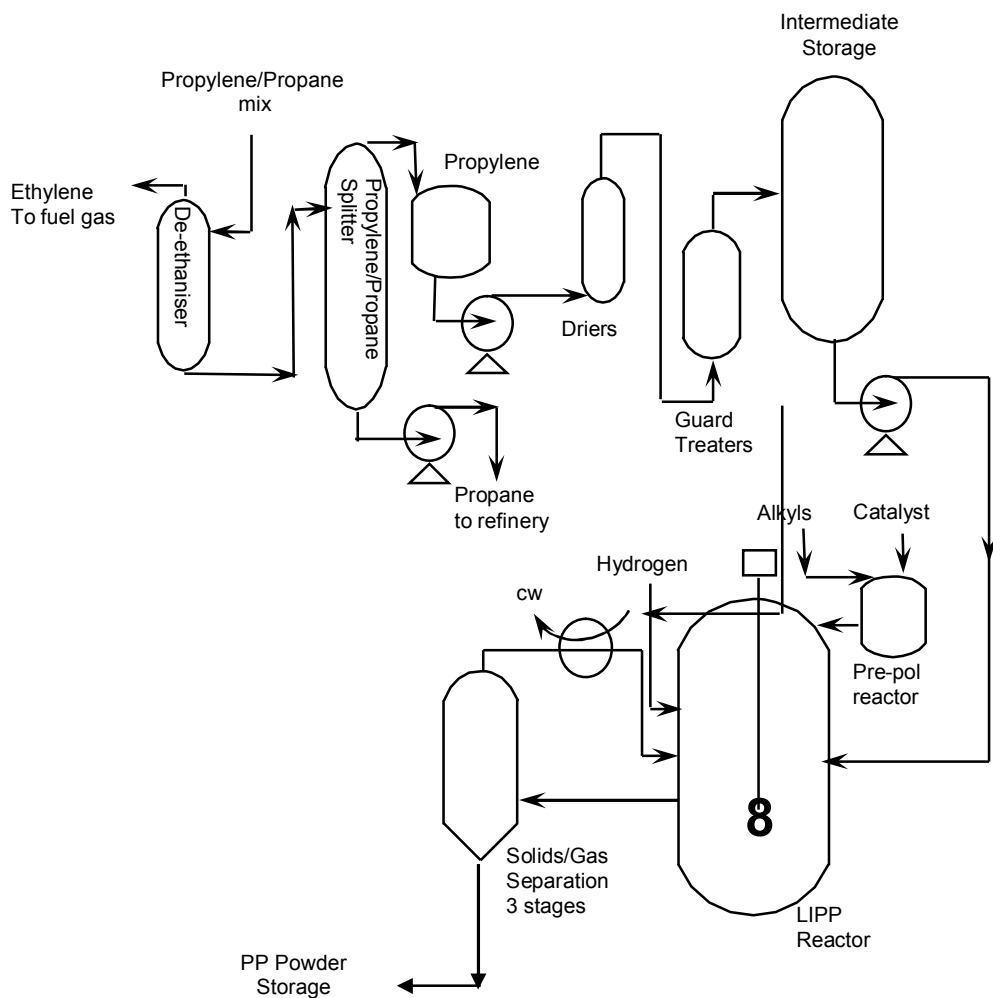

Flow Diagram of the Liquid Propylene Pool (LiPP) process used at Geelong.

Source: LyondellBasell Australia 2009

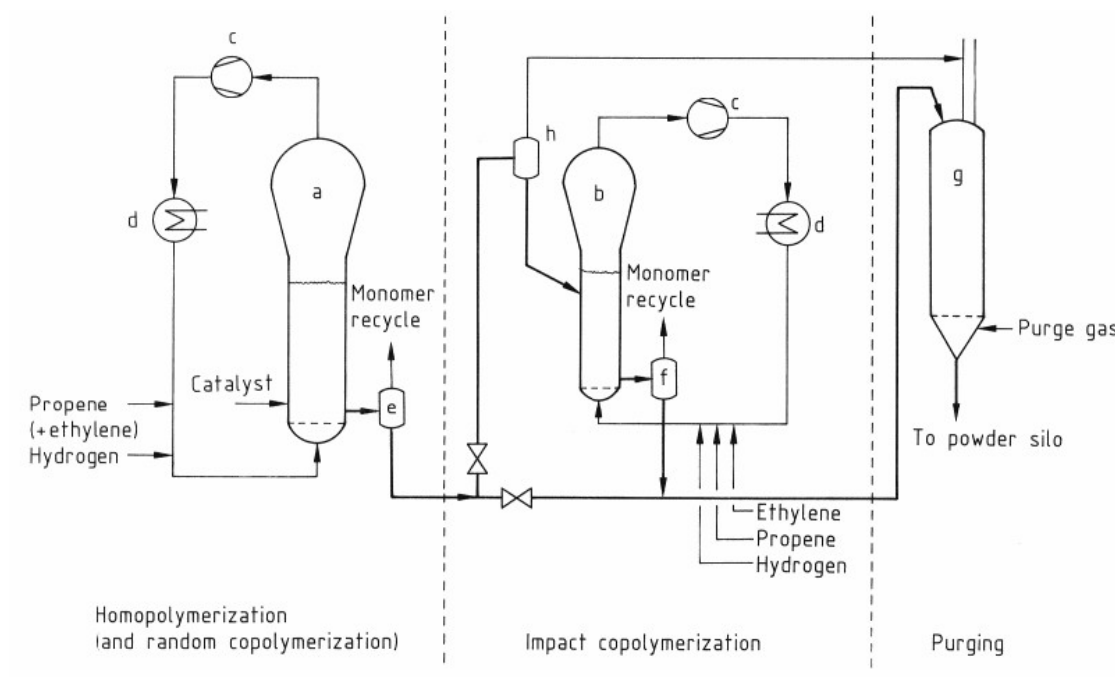

Flow diagram of the fluidized bed gas phase process as used at Clyde

Source: IPCC Reference Document on Best Available Techniques in the Production of Polymers- October 2006

Use Phase and End-of-Life Management

Use Phase

Polypropylene is one of the most commonly used and versatile plastics today and is used in both short and long life applications. Australians consumed an average of 10.6kg/person during 2008 for a total of 236,000 tonnes.¹ It is likely you will come into daily contact with an article made from PP, be it your shampoo container, food containers for margarine, yoghurt, fruit and breakfast spreads, protective films keeping food stuffs fresh, household carpets, in light weighted trim components of your car, to the banknotes used to pay for these. There are also a myriad of applications we seldom see yet benefit from, be it medical fabrics and items, materials handling items to soil erosion control grids.

The responsible use and disposal of PP will continue to be important issues. Within the plastics industry there are ongoing initiatives to monitor and manage the environmental impact that products impart along their life cycle. This is being accomplished in a variety of ways from innovations in the technologies used for PP manufacture, to aspects of product and system design, recycling infrastructure development, grade development benefits and consumer education.

End of Life Options

Within Australia there is currently only one major route available for the recovery of embedded energy within end of life PP articles, that being mechanical recycling. Energy from Waste (EfW) recycling is in its infancy in Australia while chemical recycling is currently not available in Australia. In 2008 a total of 41,036 tonnes of PP articles were recovered by the Australian recycling industry, of this amount 26,336tonnes was reprocessed in Australia with 14,699 tonnes exported for recycling¹.

Mechanical recycling conducted in Australia involves collection, sorting grinding and re-pelletising for re-use. Established recycling schemes are in place for post industrial articles and, more recently, for post consumer packaging waste. PP (type 5) plastic packaging articles are now accepted by local councils servicing over 73% of Australia's population¹.

In Australia, there are some 33¹ companies collecting (and competing for) available Polypropylene scrap from industry, and, more recently from Municipal Recovery Facilities (MRFs) that collect and sort PP post consumer waste from council kerb side collection schemes. The process involves collection, sorting, baling then size reduction into flake (film and sheet) or granules which may then need washing and drying. This is then re-compounded with additives and/or more virgin raw material, extruded and chopped into pellets ready for reuse. An industry study funded by the NPC into the recovery and recycling of PP articles confirmed that it was both technically and commercially viable enabling its' reuse into an existing myriad of applications.²

Examples of PP recycling include:-

- Automotive battery cases where the batteries are collected at the end of their life, the lead and acid recovered, and the PP battery case material is recycled. This recycled material typically goes back into new automotive battery cases and can also be used in other applications.
- Australian banknotes are made from PP and upon their withdrawal from use are collected from Banking Institutions then granulated into small pieces. These pieces are then re-melted and formed into pellets ready to be used as a raw material for a range of new products.
- Municipal Kerbside Collected packaging items such as used ice cream, yoghurt and margarine containers, spreads/dip containers, cordial bottles, personal care containers, laundry product containers and more.
- Materials handling applications such as pallets, crates, containers and tote boxes. These multi use durable applications are sought after by the recycling industry as a source of feedstock for recycled PP. Recycling companies will typically form collection deals with major sources of such items.

Although PP like other thermoplastics is capable of being recycled, for a multitude of reasons some of it will end up in landfill. Landfill is the least preferred end result for a variety of reasons, however, in isolated areas or where the costs and energies required to transport and recycle waste outweigh the benefits, this may be a better option than currently available recycling methods. PP is inert under landfill conditions; it does not contribute to leaching in landfill sites, does not generate methane gas and is stable within the landfill.

There is a variety of safe ways to handle end of life PP articles, depending on the circumstances. If large and relatively clean streams are available and can be collected in an economically viable way, recycling is the preferred option. Alternatively, the high calorific content of the material offers potential for use as a valuable feedstock in possible future energy recovery facilities.

Environmental Performance

The production of 1 kg of polypropylene granules from “well to gate” is associated with environmental impacts as represented by the following performance indicators.

Input Parameters

Indicator	Unit	Value
Non-renewable materials		
• Minerals	kg	0.0082
• Fossil fuels	kg	1,810
• Uranium	kg	2.38E-7
Renewable materials (biomass)	kg	0.0254
Water use ¹⁾	kg	5.03
Non-renewable energy resources ²⁾		
• for energy	MJ	22.1
• for feedstock	MJ	51
Renewable energy resources (biomass) ²⁾		
• for energy	MJ	0.7
• for feedstock	MJ	0
¹⁾ This indicator is predominantly process cooling losses.		
²⁾ Calculated as upper heating value (UHV).		

Output Parameters

Indicator	Unit	Value
GWP	kg CO ₂	2.17
ODP	g CFC-11	n/a ³⁾
AP	g SO ₂	11.00
POCP (CML 2002)	g C ₂ H ₄	0.42
NP (CML 2002)	g PO ₄	1.3
Total particulate matter	g	0.62
Waste		
• Non-hazardous	Kg	0.0295
• Hazardous	Kg	0.0002
³⁾ Relevant LCI entries are below quantification limit.		

Data Sources and Allocation

The data in the above input and output tables refers to polypropylene produced in the Australian manufacturing plants of LyondellBasell Australia Pty Ltd. (LBA). The LCI data was generated by RMIT Centre for Design in Sep 2011 and was done in accordance with ISO14040/14044. In accordance with the standards the data has been independently peer reviewed by Franklin Associates.

Data for hydrocarbon sources, types, precursors, ancillary operations and transport were obtained from local manufacturers and operators as well as publicly available LCI databases. Mass allocation was used for multi-output processes. Vertical averaging was performed to take into account company- and site-specific production routes.

Additional Environmental and Health Information

Sustainability Covenant

LBA has signed the covenant with partners of EPA Victoria and PACIA. The key tenants of this agreement are to enhance sustainability via:-

- Increasing the efficiency with which we use resources to produce products and services.
- Reduce the ecological impact of those products & services throughout the life cycle.

www.epa.vic.gov.au

ISO14001

Australian PP manufacturing sites are accredited to this international environmental management standard and are regularly audited by a third party external agency to ensure ongoing accreditation.

National Packaging Covenant

As an active signatory LBA is committed to the principals of the covenant and its goal of increasing the efficiency in which plastics are used for packaging over the whole life cycle.

www.packagingcovenant.org.au

Responsible Care®

The Responsible Care program initiated by the chemical industry provides a structured commitment to enhanced HSE performance. Responsible Care has been adopted by LBA manufacturing, research & development and marketing activities.

<http://www.responsiblecare.org>

Data Availability

For copies of this EID, for the underlying LCI data or for additional information, please contact Lyondell-Basell Australia Pty Ltd.

LCI data has been made available to AusLCI for inclusion into the Australian LCI database.

www.auslci.com.au

Information

Program Sponsor

LyondellBasell Australia Pty Ltd

Level 5, 627 Chapel Street
South Yarra Vic 3141
Telephone: (03) 9829 9455, Fax: (03) 9829 9531.
www.polymers.lyondellbasell.com

Program Manager

RMIT Centre for Design

The LCI data used within this EID was compiled and evaluated by RMIT with the cooperation of Lyondell-Basell Australia Pty Ltd.

Peer Review

Franklin Associates

The LCI data and methodology used was independently reviewed to ISO14040/14044 by Franklin Associates.

www.fal.com

References

1. *PACIA: National Plastics Recycling Survey 2009.*
www.pacia.org.au
2. *National Packaging Covenant: A Study into the Economic Viability of recycling post consumer PP waste.*
www.packagingcovenant.org.au
3. *Green Marketing and Trade Practices Act. Published by the ACCC 02/08.*
www.accc.gov.au

Glossary

AusLCI – The Australian National Life Cycle Inventory Database (AusLCI) is an initiative of the Australian Life Cycle Assessment Society (ALCAS). The aim is to provide and maintain a national, publicly-accessible database of environmental information on a wide range of Australian products and services over their entire life cycle.

Acidification potential, AP — An environmental impact category (“acid rain”). Emissions (e.g. sulphur oxides, nitrous oxides, ammonia) from transport, energy generation, combustion processes, and agriculture cause acidity of rainwater and thus damage to woodlands, lakes and buildings. Reference substance: sulphur dioxide.

Environmental Protection Authority, EPA – A statutory authority established under the Environmental Protection Act of 1970. Purpose is to protect, care for and improve the environment.

Global warming potential, GWP — An environmental impact category (“greenhouse effect”). Energy from the sun drives the earth’s weather and climate, and heats the earth’s surface. In turn, the earth radiates energy back into space. Atmospheric greenhouse gases (water vapour, carbon dioxide, and other gases) are influencing the energy balance in a way that leads to an increased average temperature on earth’s surface. Additional greenhouse effects caused by human activities may further increase the average global temperature. The index GWP is calculated as a multiple equivalent of the absorption due to the substance in question in relation to the emission of 1 kg of carbon dioxide, the reference substance, over 100 years.

Polypropylene (PP) — A thermoplastics polyolefin with a density around 900 kg/m³. Thermoplastic consisting of bound propylene units. (C₃H₆)_n

Life Cycle Assessment, LCA — A standardised management tool (ISO 14040–44) for appraising and quantifying the total environment impact of products or activities over

their entire life cycle of particular materials, processes, products, technologies, services or activities.

Life Cycle Inventory, LCI – A standardised set of data relating to the environmental inputs, outputs and impacts involved in the production of a given amount of a product or service. Collected in accordance with ISO14040-44 standards. Used as base data in LCAs.

Nutrication potential, NP — An environmental impact category (“over-fertilisation”). Emissions such as phosphate, nitrate, nitrous oxides, and ammonia from transport, energy generation, agriculture (fertilisers) and wastewater increase the growth of aquatic plants and can produce algae blooms that consume the oxygen in water and thus smother other aquatic life. This is called eutrophication and causes damages to rivers, lakes, plants, and fish. Reference substance: phosphate.

Offsetting — Financing activities which compensate the climate effect (and often at the same time also the use of non-renewable resources) resulting from the production.

Ozone depletion potential, ODP — An environmental impact category (“ozone hole”). The index ODP is calculated as the contribution to the breakdown of the ozone layer that would result from the emission of 1 kg of the substance in question in relation to the emission of 1 kg of CFC-11 (a Freon) as a reference substance.

Plastics & Chemical Industry Association, PACIA – The peak representative body of the Plastics industry.

Photochemical ozone creation potential, POCP — An environmental impact category (“summer smog”). The index used to translate the level of emissions of various gases into a common measure to compare their contributions to the change of ground-level ozone concentration. The index POCP is calculated as the contribution to ozone formation close to the ground due the substance in question in relation to the emission of 1 kg of ethene as a reference substance.

All information (“Information”) contained herein is provided without compensation and is intended to be general in nature. You should not rely on it in making any decision. LyondellBasell accepts no responsibility for results obtained by the application of this Information, and disclaims liability for all damages, including without limitation, direct, indirect, incidental, consequential, special, exemplary or punitive damages, alleged to have been caused by or in connection with the use of this Information. LyondellBasell disclaims all warranties, including, but not limited to, the implied warranties of merchantability and fitness for a particular purpose, that might arise in connection with this information.