

Assembly, Operating & Maintenance Instructions

STAPLES

Staples Calor 2 Lever Drafting Chair

Re-Order Code: 19031539

Remove all items from the carton. Verify all pieces before assembly.

PARTS LIST

KEY	QTY	DESCRIPTION
1	5	Castors
2	1	Chair Base
3	1	Gas Lift
4	1	Footring
5	1	Seat
6	1	Seat Mechanism
7	1	Back

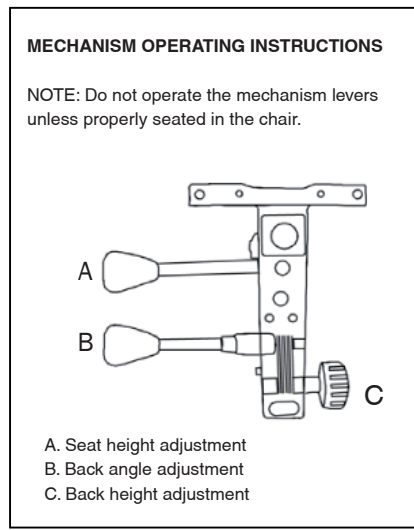
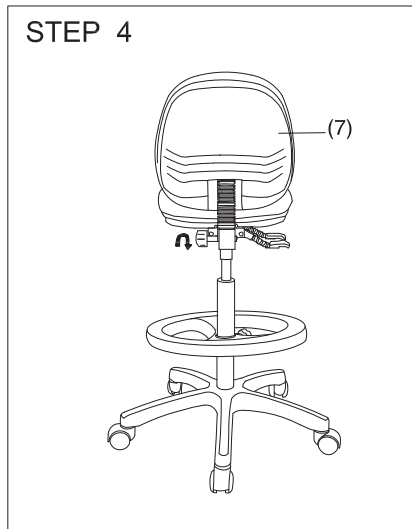
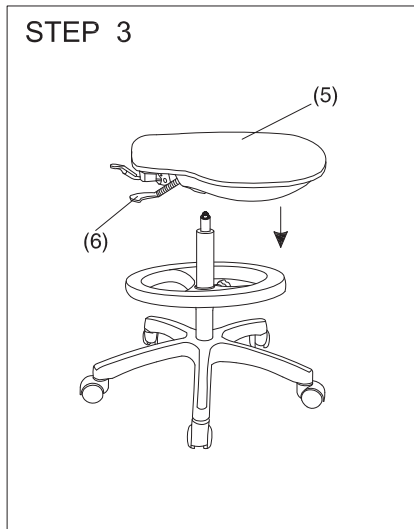
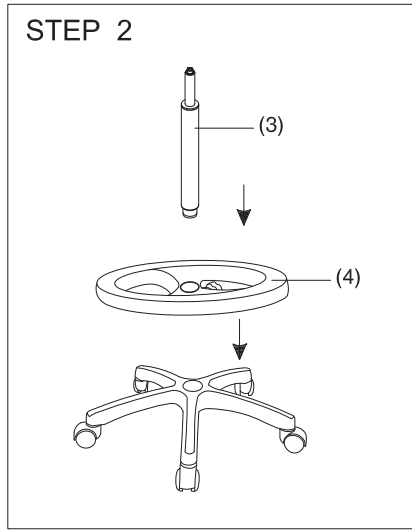
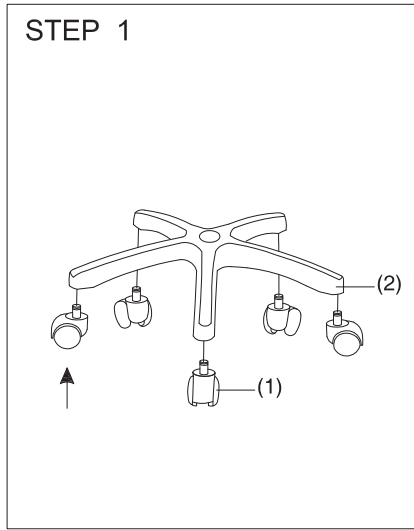

CARE & MAINTENANCE

GENERAL CARE

- To maintain the appearance of non-upholstered parts wipe the surface with a clean cloth dampened with a mild detergent solution
- Do not remove any parts for separate cleaning
- Do not saturate the fabric or interior with water or other cleaning liquids
- Do not shampoo clean
- Do not clean with hot water extraction machine
- Do not clean with onsite drycleaning machine
- Protect from direct sunlight, heat and weather.

UPHOLSTERY CARE FOR FABRIC

- Wipe with a clean cloth dampened with a mild upholstery detergent solution
- A soft bristle brush may be used to remove ingrained soil
- Spot clean as above. Treat spills and stains as soon as possible
- Persistent stains may require treatment by a professional cleaner
- May be cleaned with dry powder cleaners
- Allow to dry thoroughly before reuse.

UPHOLSTERY & FOAM SPECS

FOAM

Flame Resistant: Ca117 Section A Part I & Section D Part II

UPHOLSTERY: FABRIC

Flame Resistance: Ca117 Section E Class I

RECOMMENDED SEATING POSITION & OPERATING INSTRUCTIONS:

To ensure maximum enjoyment, comfort & safety when using this chair, please familiarise yourself with the following recommended seating positions & operating instructions as detailed below;

- Sit on the chair to operate the chair functions.
- Lift the right hand Gas lift lever paddle (A) to lower the seat to the desired seat height position. To raise the seat, lift the right hand Gas lift lever paddle (A) while supporting your own weight off the seat.

NOTE: A suitable seat height position may be influenced by your working environment e.g. the height of the work surface. Your forearms should be as close to horizontal as possible when working at your work surface & your feet should be resting flat on the floor or on a solid surface.

- While seated in your chair (at its lowest seat height) lift the back tilt lever (B) to adjust your back angle (forward or rearward) to the desired position. When the desired back angle is found, it is recommended that the back be locked into this position by pressing down on the back tilt lever until the lever locks down - refer safety instructions below.
- Adjust the back height by tightening the back knob (C) and slowly raise or lower the back (7) to the preferred height. When desired back height is found, tighten back knob (C) firmly.

- Loosen the centre footring knob by rotating anti-clockwise and then slide the footring up or down the gaslift column to the desired height. Firmly tighten the centre knob clockwise to secure the footring into place.

NOTE: A suitable footring height is achieved when your feet are resting flat on the footring providing maximum comfort and support in your seated position.

SAFETY NOTE: To avoid tipping: a) Only adjust the back angle of the Staples Calor Drafting Chair when the seat height is in the lowest position and your feet are firmly on the floor. Always keep your back tilt mechanism LOCKED when raising the Stool to bench height. b) Avoid using the footring as a ladder when ascending or descending the Staples Calor Drafting Chair. Using a fixed flat surface, bench or working surface is highly recommended for this operation.

PREVENTATIVE MAINTENANCE & WARNING!

- Do not use this chair as a step stool/ladder.
- Do not sit on any part of the chair except the seat.
- Do not use this chair on uneven floor surfaces.
- Do not open, heat up or interfere with the operation of the gas lift
- Do not use chair unless all bolts, screws and knobs are tight. At least every three months check all bolts, screws and knobs to ensure they are tight.
- If any parts are missing, broken, damaged or worn do not use the product until repairs are made using factory authorised parts.
- Dispose of packaging properly.
- Plastic bags used for packaging are not toys.
- Do not use plastic bag as a head covering as it may cause suffocation.
- Failure to follow these warnings could result in serious injury.
- Use this product only for seating one person at a time.
- Indicative Weight Usage: 110kg
- Indicative daily sitting hours: 6-8 hrs