

Assembly, Operating & Maintenance Instructions



Staples Calor Chair

Re-Order Codes:

Without arms - 18934987 With arms - 19031681

Remove all items from the carton. Verify all pieces before assembly.

PARTS LIST

KEY	QTY	DESCRIPTION
1	5	Castors
2	1	Chair Base
3	1	Gas Lift
4	1	Gas Lift bellows
5	1	Seat
6	1	Seat Mechanism
7	1	Back
8*	6	Arm Screws
9*	6	Arm Washers
10*	1	Allen Wrench
11*	2	Arms

* Parts required for chairs purchased with arms only.

CARE & MAINTENANCE

GENERAL CARE

• To maintain the appearance of non-upholstered parts wipe the surface with a clean cloth dampened with a mild detergent solution • Do not remove any parts for separate cleaning • Do not saturate the fabric or interior with water or other cleaning liquids • Do not shampoo clean • Do not clean with hot water extraction machine • Do not clean with onsite drycleaning machine • Protect from direct sunlight, heat and weather.

UPHOLSTERY CARE FOR FABRIC

Wipe with a clean cloth dampened with a mild upholstery detergent solution • A soft bristle brush may be used to remove ingrained soil • Spot clean as above. Treat spills and stains as soon as possible • Persistent stains may require treatment by a professional cleaner • May be cleaned with dry powder cleaners • Allow to dry thoroughly before reuse.

UPHOLSTERY & FOAM SPECS

FOAM

Flame Resistant: Ca117 Section A Part I & Section D Part II

UPHOLSTERY: FABRIC

Flame Resistance: Ca117 Section E Class I

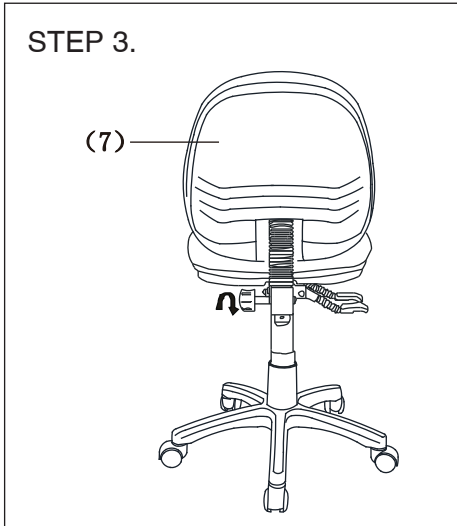
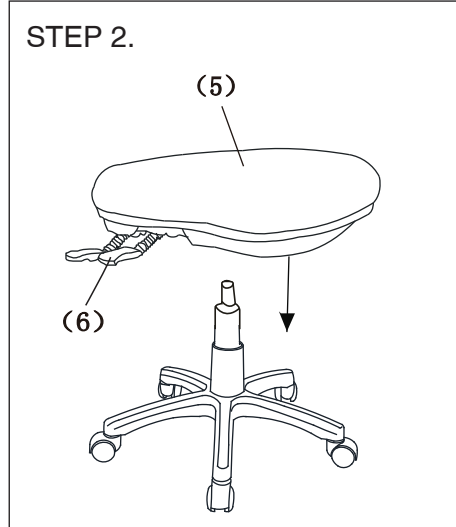
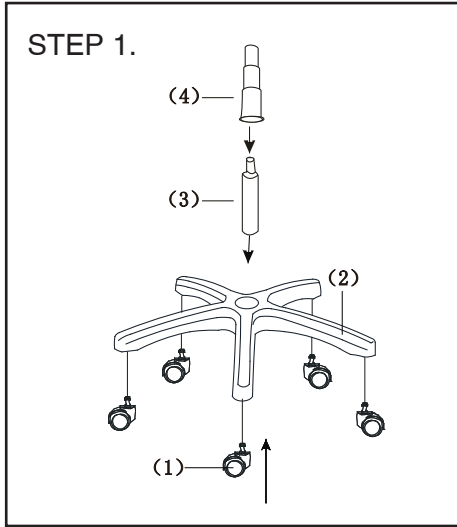

MECHANISM OPERATING INSTRUCTIONS

NOTE: Do not operate the mechanism levers unless properly seated in the chair.

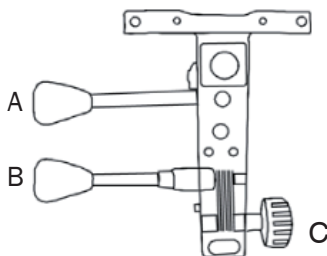

- A. Seat height adjustment
- B. Back angle adjustment
- C. Back height adjustment

ARMS:

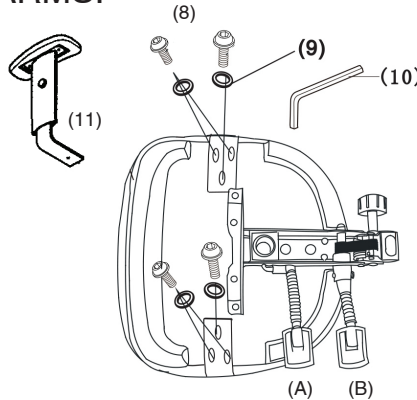

* Arm assembly instructions are for Calor chairs purchased with arms only.

RECOMMENDED SEATING POSITION & OPERATING INSTRUCTIONS:

To ensure maximum enjoyment, comfort & safety when using this chair, please familiarise yourself with the following recommended seating positions & operating Instructions as detailed below;

1. Sit on the chair to operate the chair functions
2. Lift the right hand Gas lift lever paddle (A) to lower the seat to the desired seat height position. To raise the seat, lift the right hand Gas lift lever paddle (A) while supporting your own weight off the seat.

NOTE: A suitable seat height position maybe influenced by your working environment e.g. the height of the work surface. Your forearms should be as close to horizontal as possible when working at your work surface & your feet should resting flat on the floor or on a solid surface.

3. While seated in your chair "Lift the back tilt lever (B) to adjust your back angle (forward or rearward) to the desired position. When the desired back angle is found, it is recommended that the back be locked into this position by pressing down on back tilt lever until the lever locks down.

NOTE: The back tilt feature is an important operational feature of the chair to help promote good posture & support. We recommend it's use as often as is necessary when different seating positions are required during the working day.

4. Adjust the back height by untightening the back knob (C) and slowly raise or lower the back (7) to the preferred height. When desired back height is found, tighten back knob (C) firmly.

5. Where Adjustable Arms are fitted to your chair, they can be adjusted in height. To adjust the arm height, lift & hold the arm button and move raise or lower the arm to the desired height.

PREVENTATIVE MAINTENANCE & WARNING!

- Do not use this chair as a step stool/ladder.
- Do not sit on any part of the chair except the seat.
- Do not use this chair on uneven floor surfaces.
- Do not open, heat up or interfere with the operation of the gas lift
- Do not use chair unless all bolts, screws and knobs are tight. At least every three months check all bolts, screws and knobs to ensure they are tight.
- If any parts are missing, broken, damaged or worn do not use the product until repairs are made using factory authorised parts.

- Dispose of packaging properly.
- Plastic bags used for packaging are not toys.
- Do not use plastic bag as a head covering as it may cause suffocation.
- Failure to follow these warnings could result in serious injury.
- Use this product only for seating one person at a time.
- Indicative Weight Usage: 110kg
- Indicative daily sitting hours: 6-8 hrs