

# Assembly, Operating & Maintenance Instructions

## Access Milan Meeting Room Chair

Re-Order Code: Black 25202553 / Tan 25202554

Remove all items from the carton. Verify all pieces before assembly.

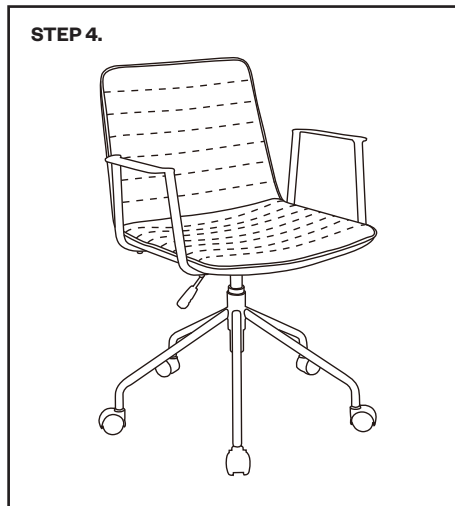
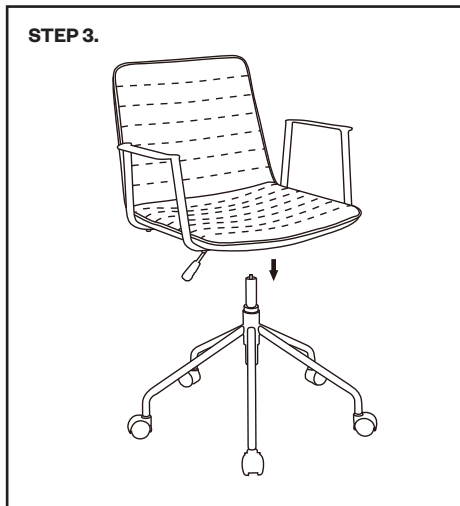
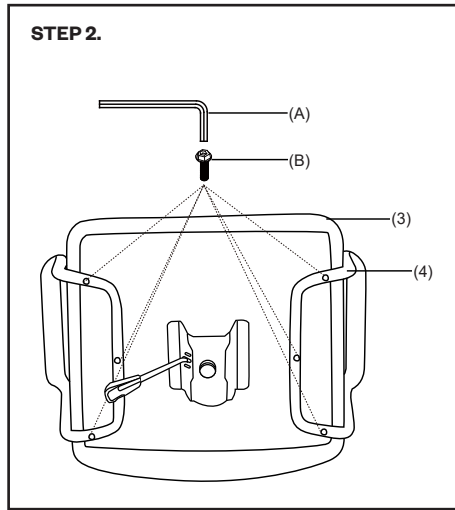
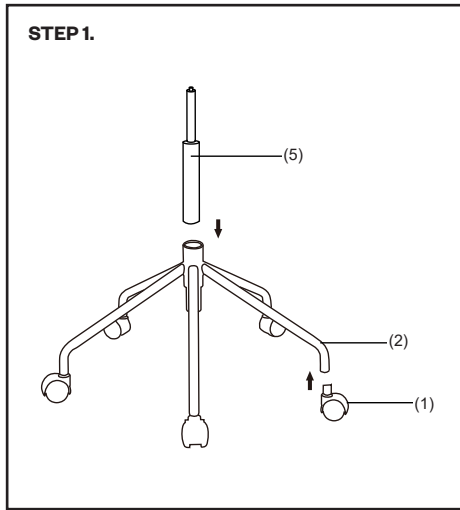

### PARTS LIST

KEY	QTY	DESCRIPTION
1	5	Castors
2	1	Star Base
3	1	Seat and Backrest
4	2	Arms
5	1	Gaslift
A	1	Allen Key
B	6	Screw (6.4mmx31.8mm)

### CARE & MAINTENANCE

#### GENERAL CARE

- To maintain the appearance of non-upholstered parts wipe the surface with a clean cloth dampened with a mild detergent solution.
- Do not remove any parts for separate cleaning.
- Do not saturate the fabric or interior with water or other cleaning liquids.
- Do not shampoo clean.
- Do not clean with hot water extraction machine.
- Do not clean with onsite drycleaning machine.
- Protect from direct sunlight, heat and weather.

#### UPHOLSTERY CARE FOR PU/PVC

- Wipe with a clean cloth dampened with a mild upholstery detergent solution.
- Use only vinyl care products suitable for upholstery vinyl and strictly in accordance with the manufacturer's instructions.
- Spot clean as above.
- Treat spills and stains as soon as possible.
- Persistent stains may require treatment by a professional cleaner.
- Allow to dry thoroughly before reuse.

### UPHOLSTERY & FOAM SPECS

#### FOAM

Flame Resistant: Ca117 Section A Part I & Section D Part II

#### UPHOLSTERY: PU/PVC

Flame Resistance: Ca117 Section E Class I

\*This applies only to standard Winc stock. Any customer specified upholstery may not meet these specifications.

### PREVENTATIVE MAINTENANCE & WARNING!

- Do not use this chair as a step stool/ladder.
- Do not sit on any part of the chair except the seat.
- Do not use this chair on uneven floor surfaces.
- Do not open, heat up or interfere with the operation of the gas lift.
- Do not use chair unless all bolts, screws and knobs are tight. At least every three months check all bolts, screws and knobs to ensure they are tight.
- If any parts are missing, broken, damaged or worn do not use the product until repairs are made using factory authorised parts.
- Dispose of packaging properly.
- Plastic bags used for packaging are not toys.
- Do not use plastic bag as a head covering as it may cause suffocation.
- Failure to follow these warnings could result in serious injury.
- Use this product only for seating one person at a time.
- Indicative Weight Usage: 110kg
- Indicative daily sitting hours: 4