

Assembly, Operating & Maintenance Instructions

PROED QUEST ARCHITECTURAL KIT

(for use on ProEd Quest Task Chair)

ProEd

Remove all items from the carton. Verify all pieces before assembly.

STEP 1

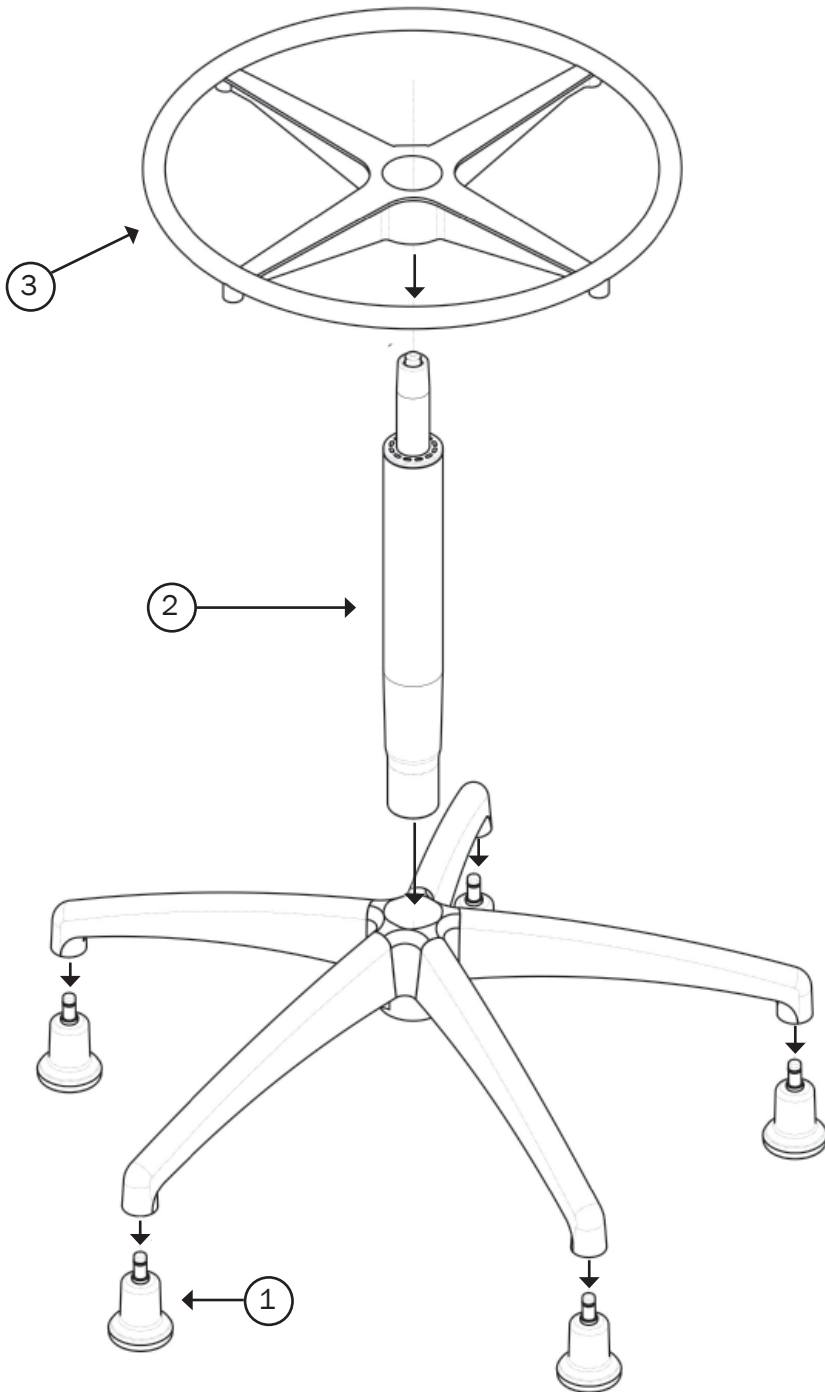

LIST

KEY	QTY	DESCRIPTION
1	5	Glides
2	1	Gas Lift
3	1	Footring

Note: The chair base pictured is not supplied with the ProEd Architectural Kit.

CARE & MAINTENANCE

GENERAL CARE

To maintain the appearance of non-upholstered parts wipe the surface with a clean cloth dampened with a mild detergent solution.

Do not remove any parts for separate cleaning.

Do not saturate the fabric or interior with water or other cleaning liquids.

Do not shampoo clean.

Do not clean with hot water extraction machine.

Do not clean with onsite drycleaning machine.

Protect from direct sunlight, heat and weather.

PREVENTATIVE MAINTENANCE & WARNING!

- Use this product only for seating one person at a time.
- Do not use this chair as a step stool/ladder.
- Do not sit on any part of the chair except the seat.
- Do not use this chair on uneven floor surfaces.
- Do not interfere with the operating of the gas lift.
- Do not operate the levers while not sitting on the chair.
- Keep hands and fingers well clear of all moving parts.
- Do not use chair unless all bolts, screws and knobs are tight. At least every six months check all bolts, screws and knobs to ensure they are tight.
- If any parts are missing, broken, damaged or worn do not use the product until repairs are made using factory authorised parts.
- Dispose of packaging properly.
- Do not use plastic bag as a head covering as it may cause suffocation. Plastic bag is not a toy.
- Failure to follow these warnings could result in serious injury.